

# Lighting Design with Efficiency

**TOMORROW IS TODAY**

James R Benya, PE,  
FIES, FIALD, LC



A special presentation of the Energy Center of Wisconsin



# Lighting Equipment

A special presentation of the Energy Center of Wisconsin

# Qualities of a Light Source

- **Efficacy** *efficiency in lumens per watt*
- **Color** *color temperature and color rendering*
- **Lamp Life** *average hours of life*
- **Temperature Sensitivity** *applicability issues*
- **Starting and Warm Up** *ranges from instant to several seconds*
- **Restarting** *ranges from immediate to ten minutes*
- **Dimming** *some do, some don't, some have issues*
- **Cost** *ranges from 10¢ to \$5.00 per million lumen hours*

A special presentation of the Energy Center of Wisconsin

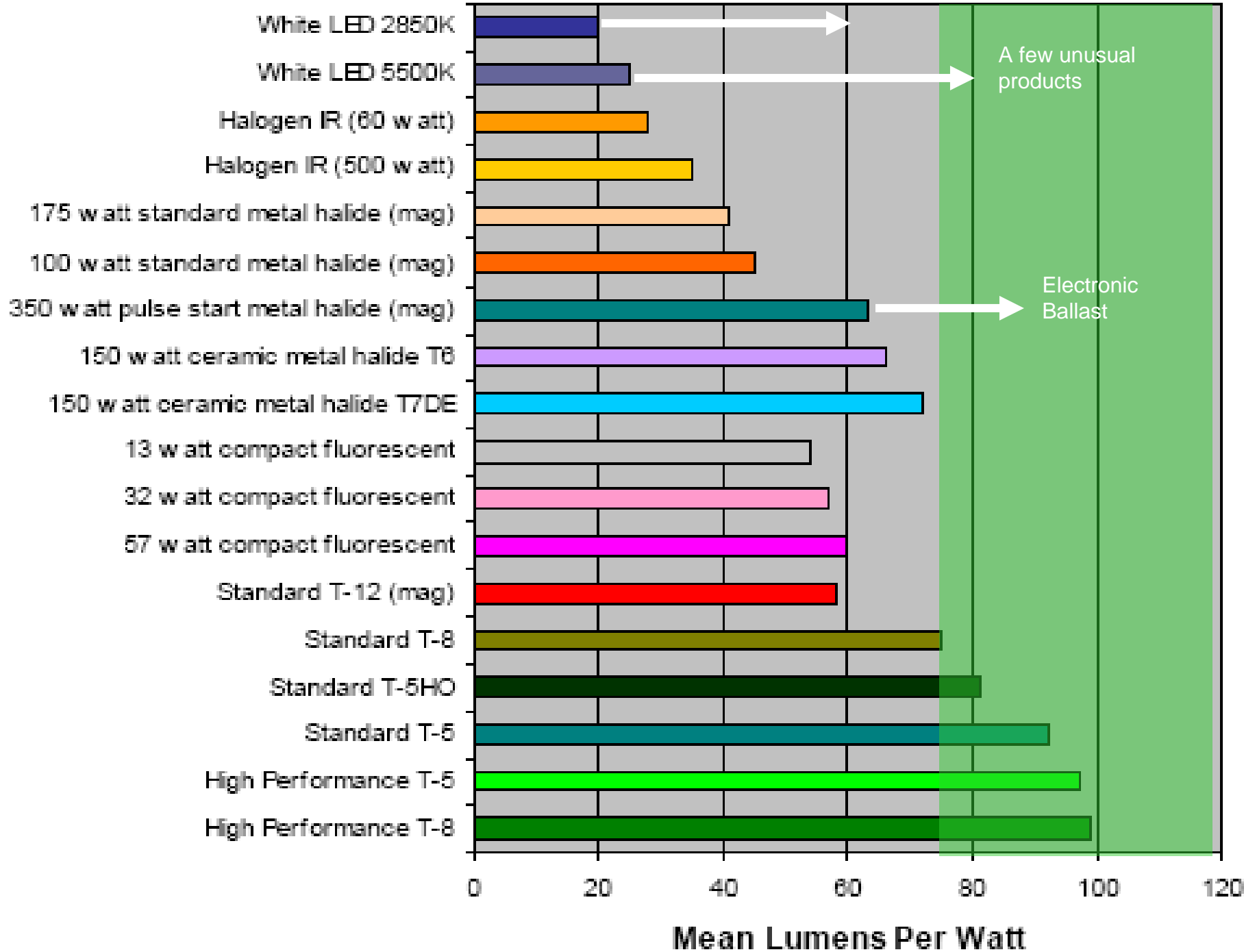

# Tungsten Lighting

- **Efficacy** *poor, most less than 30 lumens per watt*
- **Color** *excellent color rendering at 2700-3100K*
- **Lamp Life** *short (500 hours) to medium (6000 hours)*
- **Temperature Sensitivity** *none*
- **Starting and Warm Up** *instant*
- **Restarting** *instant*
- **Dimming** *dims well with color temperature shift*
- **Cost** *50¢ to \$1.00 per million lumen hours*

# *Standard Incandescent Lamps*



- Appealing
- Warm, attractive color (2600-2900K)
- Dimmable
- Wide variety of shapes, wattages
- Not energy efficient



# *Low Voltage Incandescent Lamps*

- Most operate at 6, 12 or 24 volts
- Usually low wattage but not inherently energy efficient; most lamps 5 to 50 watts
- Greatest advantage: small size

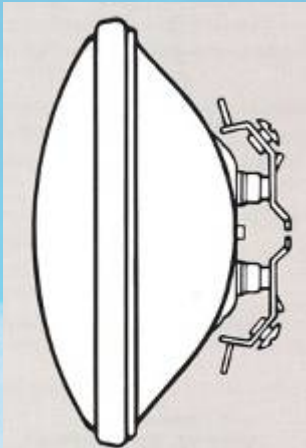

# *Halogen Lamps*

- Appealing
- Crisp warm, attractive color (2800-3100K)
- Dimmable
- Wide variety
- Longer life, slightly more energy efficient than incandescent; IR versions even better



# *Low Voltage Halogen*



- Compact, bright lamps
- A bit more energy efficient; IR versions even better
- Excellent focal, accent and display light sources
- Color Temp: 2900-3100K
- Long life



A special presentation of the Energy Center of Wisconsin

# Fluorescent Lamps



- **Efficacy** *good to superior, up to over 100 lumens per watt*
  - **Color** *good to excellent; choose color temp and CRI 80-90*
  - **Lamp Life** *very long with some versions now 42,000 hours*
  - **Temperature Sensitivity** *significant, varies with product*
  - **Starting and Warm Up** *instant or rapid, some warm up*
  - **Restarting** *instant*
  - **Dimming** *expensive, but dims well with color quality shift*
  - **Cost** *10¢ (non dimming) to \$1.00 (dimming) per million lumen hours*
- 

# Linear Fluorescent Lamps



- T-8 High Performance (“super”) Lamps
  - 90-102 mean lumens per watt
  - Most lamps >80 CRI
  - Up to 42,000 hour lamp life
  - 4’ standard; 2’, 3’, 5’, and 8’ lamps available at lower efficacy
- T-5 Standard Lamps
  - 90-101 mean lumens per watt.
  - >80 CRI
  - 20,000 hours + life.
  - 4’ standard; 2’, 3’, 5’, and circle lamps available at lower efficacy
- T-5 HO Lamps
  - 80-85 mean lumens per watt
  - >80 CRI
  - 20,000 hours life.
  - 4’ standard; 2’, 3’ 5’ and circle lamps available at lower efficacy



# Compact Fluorescent Lamps



## *Special Notes*

### Pin based lamps

- Average life 10,000 hours
- External ballast part of fixture
- Dimming possible with electronic dimming ballast

### Screw/GU-24 lamps

- Average life 7,500 hours
  - Internal ballast may overheat in enclosed fixture
  - Dimming with specially rated products **ONLY**
- 

# Pin-based Compact Fluorescent



- Twin tube
- Quad (double twin) tube
- Hex (triple twin) tube and quad twin tube
- Flat quad tube
- Long Twin tube
- Minimum watts: 5
- Maximum watts: 80



# Screw Based Compact Fluorescent

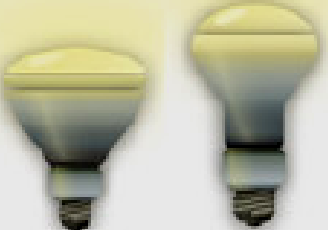

- Spiral lamps
- Variations on single/double/triple/four twin tube lamps

| Bare Products   |  | Covered Products  |   |  | Reflector Products   |
|---|--|---|---|--|--|
| Mini-Spiral or Twist  | Tube or Universal  | Incandescent/<br>A-line   | Globe G25,<br>G30, G40  | Candelabra.<br>Post or Bullet<br>Shape   | Indoor and Outdoor<br>R20, R30, R40, PAR38   |
|  |  |  |  |  |  |

# Special Screw Based Lamps



- Induction Lamps
  - Very long life >15,000 hrs
  - Medium Efficacy
  - Low maintenance
- Cold Cathode Lamps
  - Ultra long life >25,000 hrs
  - Low wattage
  - Low maintenance



# GU-24 Based Lamps

- For compact fluorescent lamps with integral ballasts
- Ensures replacement with a compact fluorescent
- Allows owner to pick lamp

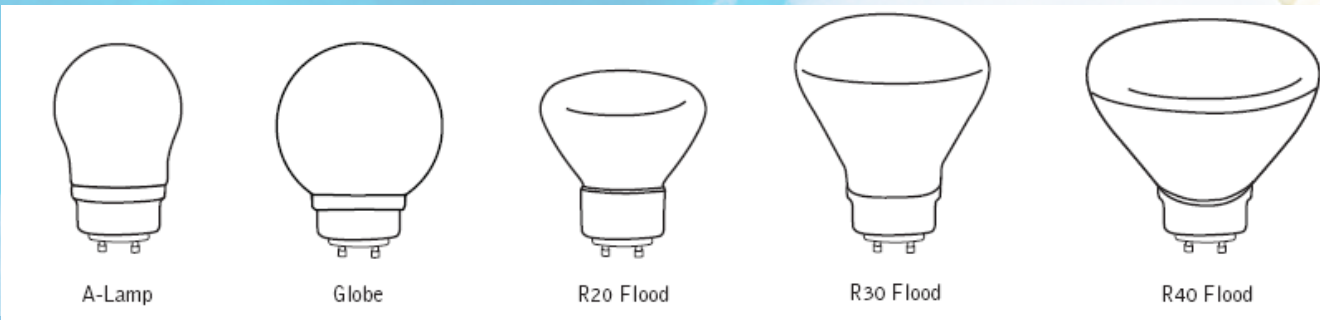
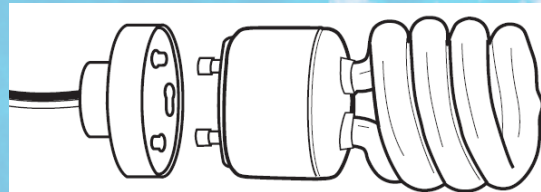

A special presentation of the Energy Center of Wisconsin

# Power Induction Lamps

- High wattage (65-150)
- High efficacy (75 mean lumens per watt)
- HID alternative
- Very long lamp life (50,000 hours+)
- Low maintenance



A special presentation of the Energy Center of Wisconsin

# LED's

- **Efficacy** *Highly variable; no standards; up to 60 lumens per watt; beware poor products*
- **Color** *poor to very good, varies considerably*
- **Lamp Life** *under proper conditions, >50,000 hours*
- **Temperature Sensitivity** *must not get hot*
- **Starting and Warm Up** *instant*
- **Restarting** *instant*
- **Dimming** *dims well with proper but expensive gear*
- **Cost** *Most expensive; \$5.00 to \$20.00 per million lumen hours*

# Option 1: LED “lamps”



- Temperature concerns
- Current products 30-50 lumens per watt
- Dimming but not like incandescent
- Limited amount of light output

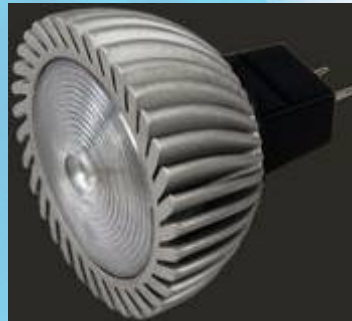

# Option 2: LED “Fixtures”

- White, colored or color changing
- Temperature concerns
- Current products 15-60 lumens per watt
- Dimming but not like incandescent
- Reasonable amount of light output

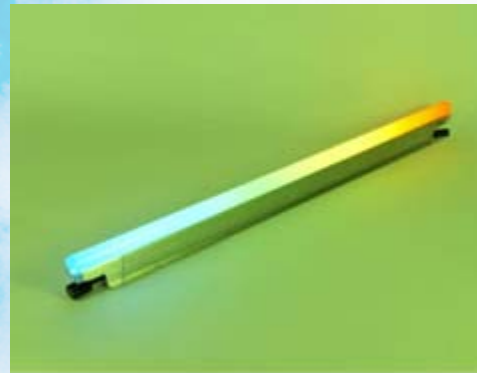

# Option 3: LED “Systems”



A special presentation of the Energy Center of Wisconsin

# High Intensity Discharge (HID) Lamps



- Mercury Vapor Lamps
  - Obsolete and now banned
  - Poor color, poor lumen maintenance
- High Pressure Sodium
  - High efficacy but poor color
  - Useful as street and security lighting due to low cost and minimum temperature sensitivity
- Low Pressure Sodium
  - No color; should only be used when needed
- Metal Halide
  - Quartz metal halide: high efficacy, mediocre color
  - Ceramic metal halide: high efficacy, **superior color**



# Ceramic Metal Halide

- **Efficacy** *good to superior, up to over 80 lumens per watt*
- **Color** *good to excellent; choose color temp and CRI 80-90+*
- **Lamp Life** *Long, 12,000-25,000 hours*
- **Temperature Sensitivity** *None significant*
- **Starting and Warm Up** *Slow start and warm up*
- **Restarting** *must wait 3-5 minutes to restrike*
- **Dimming** *not recommended, can be used for energy management purposes*
- **Cost** *50¢ to \$1.00 per million lumen hours*

# Ceramic Metal Halide



- High CRI >80
- Choice of 3000K or 4100K
- Lamps from 20 watts to 400 watts
- Choice of lamp type and shape



A special presentation of the Energy Center of Wisconsin

# Other Lamp Types



- Neon *custom made discharge tubing, long life and moderately efficient, dimmable and flashable, requires special high voltage wiring*
  - Cold Cathode *similar to neon but bigger, more lumens*
  - Fiber Optics *not really a lamp type, can be used to transmit light from an illuminator to a display*
- 



# Ballast Technology 2008

A special presentation of the Energy Center of Wisconsin

# Fluorescent Ballasts



## Non-dimming ballasts

- Standard instant start
- High efficiency instant start
- Standard program start
- High efficiency program start



## Fixed ballast factors

- Reduced light and power (0.7-0.8)
- Normal light and power (T8 ~ .88, T5/T5HO .95-1.0)
- High light and power (1.15-1.2)



# Fluorescent Ballasts

## Step dimming ballasts

- All rapid start
- 2 steps (0-50-100)
- 3 steps (0-30-70-100)
- 7 steps dissolve (3-100%)



## Analog dimming ballasts

- 0-10 volt external circuit for photocells and complex systems
- 2 wire wallbox dimmer circuit
- 3 wire legacy fluorescent dimming circuit for dimming systems



# HID Ballasts



- Electronic ballasts for all HID lighting through 150 watts, indoor and some outdoor applications
- Electronic ballasts for indoor HID lighting 250-400 watt
- Magnetic ballasts for all other HID



# LED Drivers

- Dimming and non-dimming
- Designed to power “standardized” LED’s



# Digital Lighting Controls



Plug in low voltage wiring and stations – no conduit needed

Low voltage controls 18-22 ga.wire plenum rated

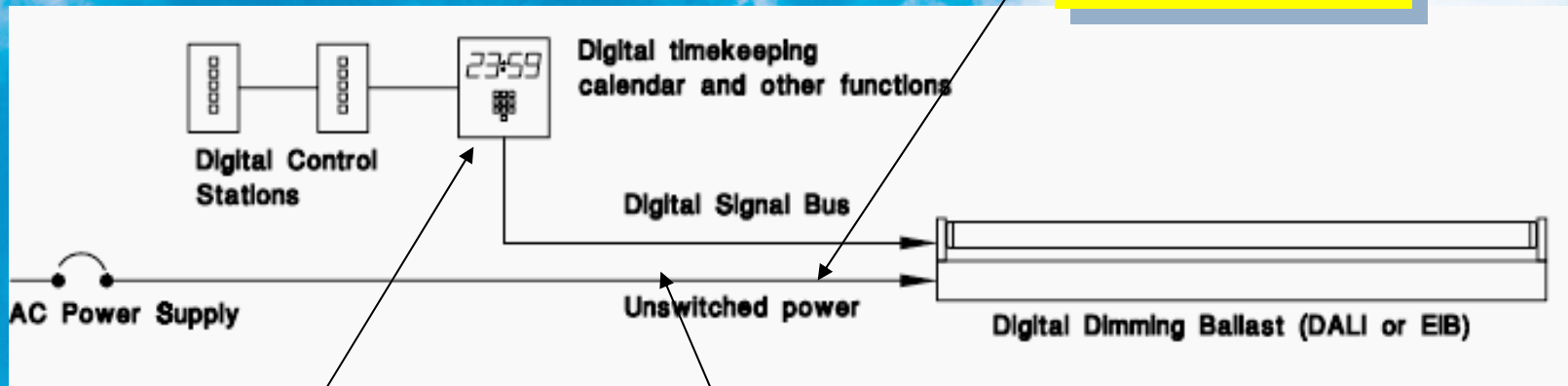

One master controller per building

Load any circuit up to 16 amps



# Digital Lighting Ballasts



## Fluorescent dimming

- Standard DALI dimming ballasts (T8, T5, CF)
- Proprietary advanced dimming ballasts
- High performance dimming ballasts
- Combination analog legacy/digital ballasts
- Legacy fluorescent dimming ballast interface

## Other Lamps

- Digital incandescent dimmer packs
- Digital dimming LED drivers
- Digital non-dimming interfaces for HID and other non dim sources





# Frankfurt 2008 Light + Building

A special presentation of the Energy Center of Wisconsin

# Statistics



- 10 buildings and pavilions
  - 135,000 attendees
  - All types of lighting and controls
    - Architectural “technical”
    - Decorative
    - Outdoor
    - Utility
- 

A special presentation of the Energy Center of Wisconsin

# My Best of Show

Decorative  
*The Glass Artichoke*



A special presentation of the Energy Center of Wisconsin

# My Best of Show

## Techno-Decorative *Rings*



A special presentation of the Energy Center of Wisconsin

# My Best of Show



Technical  
*Round Pendant T5  
lamps*



A special presentation of the Energy Center of Wisconsin

# My Best of Show

Technical  
*Round Pendant w/CF  
and T5 lamps*



A special presentation of the Energy Center of Wisconsin

# My Best of Show

## Technical *LED Fixtures*



A special presentation of the Energy Center of Wisconsin

# My Best of Show

Technical  
*LED Engines*



A special presentation of the Energy Center of Wisconsin

# My Best of Show

## Technical *LED Fixtures*



A special presentation of the Energy Center of Wisconsin

# My Best of Show

Technical  
*Flat Fixtures (T5 and  
mixed source)*



A special presentation of the Energy Center of Wisconsin

# My Best of Show

Technical

*T5 Fixtures Acrylic  
Micro-optics*



A special presentation of the Energy Center of Wisconsin

# My Best of Show

## Outdoor *LED Pole Lights*



A special presentation of the Energy Center of Wisconsin

# My Best of Show

Decorative  
*Things in Acrylic*



A special presentation of the Energy Center of Wisconsin

# My Best of Show



Techno-Decorative  
*Space age*



A special presentation of the Energy Center of Wisconsin

# My Very Best of Show



Decorative  
*LED Crystal*

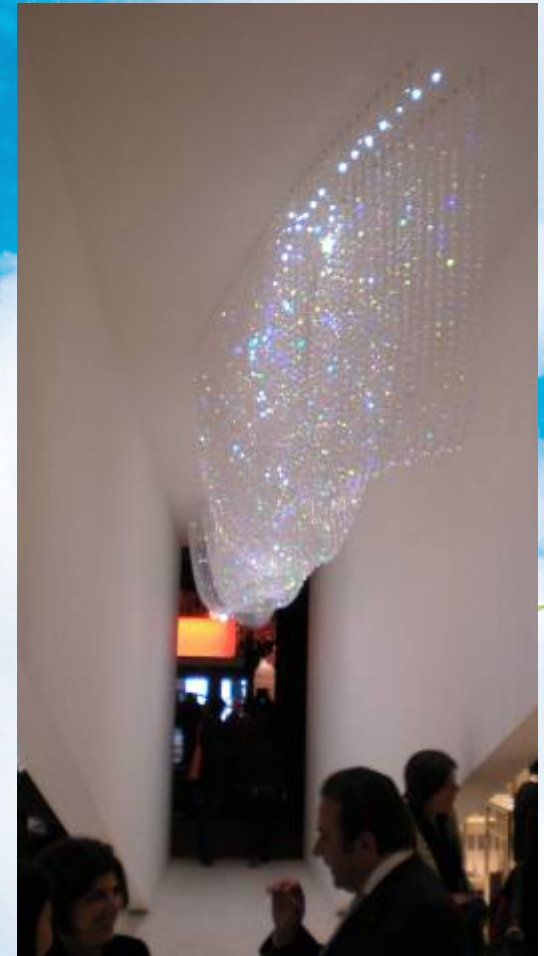

A special presentation of the Energy Center of Wisconsin



# End of Morning

[www.benyalighting.com](http://www.benyalighting.com)

A special presentation of the Energy Center of Wisconsin